



SUBMITTAL CREMCO SHIELDED TRANSITION COUPLINGS

Anaco • 675 Tyler Avenue • Marshfield, MO • 65706 • (800) 486-8188

Cremco Shielded Transition Couplings are designed to join dissimilar piping materials for DWV Plumbing Systems (cast iron, XH cast iron, plastic, steel schedule 40 plastic, SDR 35 plastic, copper and tubular). They are available in various sizes from 3/4" through 8".



Certifications & Standards

Tested & Certified to:

ASTM C 1460

ASTM C 564

CSA B602

IAPMO File 5794

Material Specifications:

Clamp: Type 301 AISI stainless steel

Screw: Type 305 AISI

Shield: Type 301 AISI stainless steel;
Shield Thickness 0.0072

Gasket: Neoprene conforming to ASTM C 564

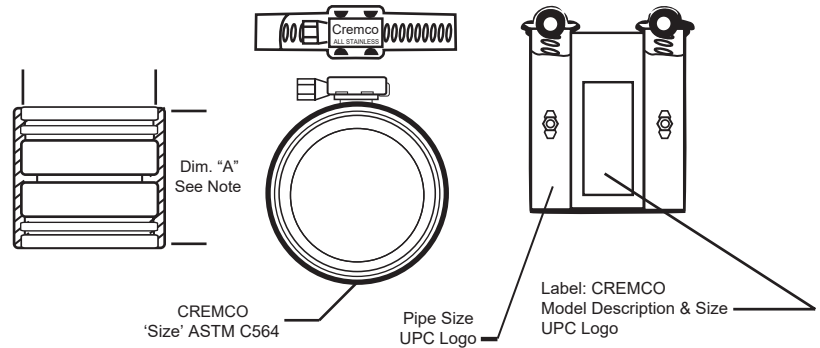

Test	Gasket Physical Tests	ASTM Method
Tensile Strength	1500 psi min.	D412
Elongation	250 min.	D412
Durometer (Shore A)	70 ± 5 @ 76° F ± 5° F	D2240
Accelerated Aging	15% maximum tensile and 20% maximum elongation deterioration, 10 points maximum increase in hardness, all determinations after oven aging for 96 hours at 158° F	D573
Compression Set	25% maximum after 22 hours at 158° F	D395 (Method B)
Oil Immersion	80% maximum volume change after immersion in IRM 903 for 70 hours at 212° F	D471
Ozone Cracking	No visible cracking at 2 times magnification of the gasket after 100 hours exposure in 1.5 ppm ozone concentration at 100° F. Testing and inspection to be on gasket which is loop mounted to give approximately 20% elongation of outer surface.	D1149
Tear Resistance	150 lb. minimum per inch of thickness	D624
Water Absorption	20% maximum by weight after 7 days at 158° F	D471

ANACO-HUSKY.COM